

ELK
MOTOR
ELK 0601-0319 FR

CATALOGUE DE PRODUITS

www.elkmotor.com.tr
www.yilmazreducteur.fr

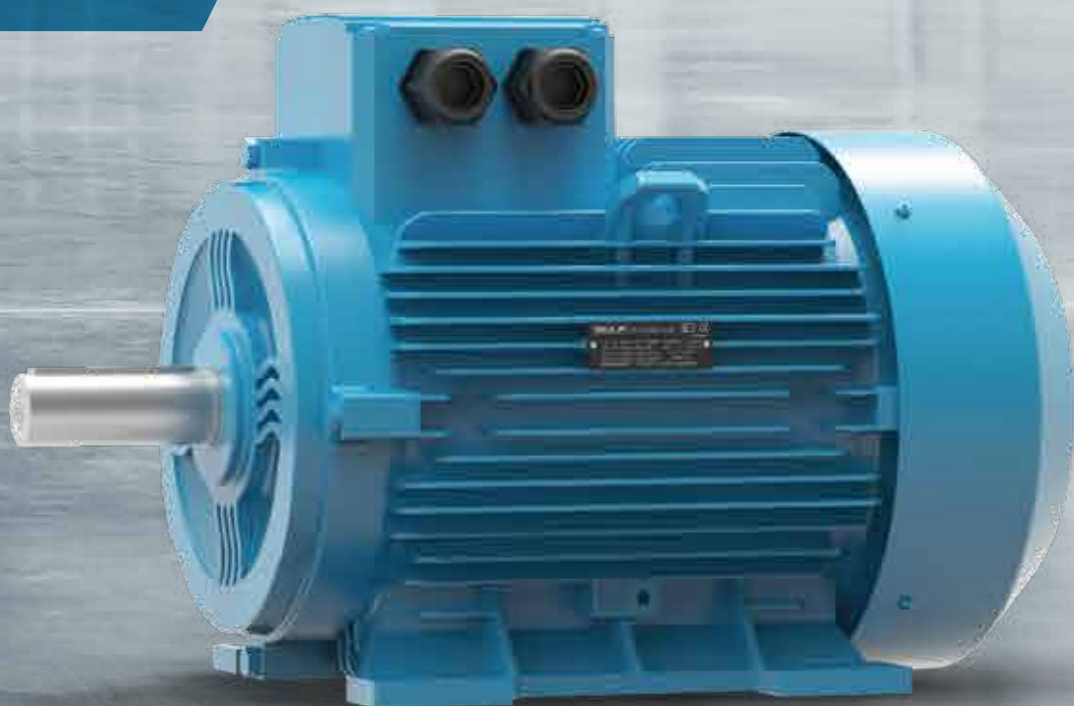

A close-up photograph of the stator windings of a motor, showing multiple layers of copper wire. The wires are arranged in a circular pattern, with some sections appearing more densely packed than others. The lighting is warm, highlighting the metallic sheen of the copper. A semi-transparent blue geometric shape, resembling a stylized 'V' or a trapezoid, is overlaid on the right side of the image, partially obscuring the windings. The text is centered within this blue area.

MOTEURS ASYNCHRONES
TRIPHASÉS À CAGE
D'ÉCUREUIL



ELK Motor a été fondé par les principaux actionnaires de Yılmaz Reduktor, dans le prolongement de la famille de produits. ELK Motor fabrique des moteurs électriques d'une taille de 71 à 280 dans une zone fermée de 40 000 m² construite sur une zone ouverte de 100 000 m².

Toutes les séries de moteurs sont conçues et fabriquées conformément aux normes européennes et dans les classes IE2 et IE3 efficiency.

La conception et la technologie principales du moteur ELK sont entièrement adaptées à la classe IE3 efficiency. Les dimensions extérieures des modèles IE3 et IE2 étant totalement identiques, le remplacement du moteur IE2 par des moteurs IE3 se fera facilement.

Parallèlement aux moteurs conformes aux normes européennes, ELK Motor fabrique également des moteurs spéciaux pour ses clients afin de réduire les coûts et d'augmenter la productivité.

Les moteurs ELK, de l'ingénierie aux processus de fabrication, sont entièrement fabriqués dans notre usine située à Çerkezköy. Les arbres de moteur et les flasques sont fabriqués par des machines CNC entièrement automatiques sous un contrôle de qualité continu. Les rotor et les stator sont fabriqués dans nos lignes de poinçonnage et d'emboîtement entièrement automatiques.

Après avoir injecté l'aluminium pur dans les noyaux de rotor dans une ligne d'injection de rotor entièrement automatique, les noyaux de rotor sont prêts pour l'assemblage. Dans les lignes d'enroulement automatiques, les noyaux de stator sont enroulés et vernis soit par la méthode d'immersion automatique, soit par la méthode VPI (imprégnation sous vide et pression) selon les besoins et le domaine d'utilisation. Ainsi, les produits sont toujours au meilleur niveau de qualité et de performance.

Après toutes ces opérations, nos moteurs, qui sont assemblés conformément aux prescriptions du produit, sont testés et contrôlés entièrement pour la dernière fois, puis expédiés aux clients après emballage.

En outre, ELK Motor dispose du système de gestion de la qualité et du produit final certifiés, dont les clients ont besoin. Notre système de qualité est certifié avec la norme ISO 9001 et nos produits ont l'approbation UL.





ELK
MOTOR





ELK
MOTOR



CONTENTS

INFORMATIONS TECHNIQUES	7
Compatibilité IEC/EN/UL	8
Construction mécanique	9
Construction électrique	10
Moteurs avec entraînement à vitesse variable	11
Moteurs dans différentes conditions ambiantes	11
Isolation du bobinage / classes d'élévation de température	12
Classes de protection	12
Types de construction	13
Roulements	14
Charges radiales	15
Charges axiales	17
LES CODES DE TYPE DE PRODUIT	21
IE2 MOTEURS	23
IE2 MOTEURS COMPACTS	26
IE3 MOTEURS	29
DIMENSIONS	33
INFORMATIONS COMPLÉMENTAIRES	37
Description de la plaque signalétique	38
Pièces de rechange	39
Thermistance CTP et interrupteur thermique	40
Chauffage	40
Anti-condensation et trou de drainage	40
Extension d'arbre d'extrémité non motrice et frein de capot, déblocage manuel, ventilateur à entraînement séparé, encodeur et anti-retour	40
	41





TECHNICAL
INFORMATION

IEC / EN / UL Compatibility

All of standard ELK Motors are designed, manufactured and tested according to the IEC and EN standards given below.

IEC 60034-1	Rating and performance
IEC 60034-2-1	Methods for determining losses and efficiency
IEC 60034-5	Classification of degrees of protection
IEC 60034-6	Methods of cooling
IEC 60034-7	Symbols of construction and mounting arrangements
IEC 60034-8	Terminal markings and direction of rotation
IEC 60034-9	Noise limits
IEC 60034-11	Built-in thermal protection
IEC 60034-14	Vibration limits
IEC 60034-18-1	Functional evaluation of insulation system
IEC 60034-30	Efficiency classes [IE Code]
IEC 60038	Standard voltages
EN 50347	Dimensions and output for electrical machines

EN 55014-1	Electromagnetic compatibility
EN 61000-3-2	
EN 61000-3-3	

UL1004-1	Rotating Electrical Machines – General Requirements
CSA C22.2 No. 100	Motors ve Generators



All of our motors, which have that UL logo on nameplate are approved by UL and manufactured according to UL1004-1 and CSA C22.2 No. 100 standards with E496161 file number.

According to IEC 60034-1, catalogue values are permitted to deviate from the real values as follows:

Speed (n)	$\Delta n = \pm 20\% (n_s - n_N), P_N > 1 \text{ kW}$ $\Delta n = \pm 30\% (n_s - n_N), P_N \leq 1 \text{ kW}$
Efficiency %(η)	$\Delta \eta = -15\% (100 - \eta_N), P_N \leq 150 \text{ kW}$ $\Delta \eta = -10\% (100 - \eta_N), P_N > 150 \text{ kW}$
Power Factor (Cos ϕ)	$\text{Cos } \phi = -1/6 (1 - \text{Cos } \phi)$
Locked rotor current (I_{LN})	$\Delta (I_{LN}) = +20\% (I_{LN})$
Starting torque (M_L/M_N)	min. $(M_L/M_N) = -15\% (M_L/M_N)$ max. $(M_L/M_N) = +25\% (M_L/M_N)$
Break down torque (M_K/M_N)	$(M_K/M_N) = -10\% (M_K/M_N)$
Moment of inertia (J) [kgm²]	$\Delta J = \pm 10\% J$
Sound pressure level (L_{PA}) [dB(A)]	$L_{PA} = +3 \text{ dB (A)}$

Mechanical Construction

71-160 frame size ELK Motors provides flexibility for different mounting types through their detachable feet which can be mounted on three sides. This feature allows terminal box assembly on the desired side. Terminal box is on the top for standard motors. 180-280 frame size motors have fixed feet construction.

MOTOR SIZE 71-160

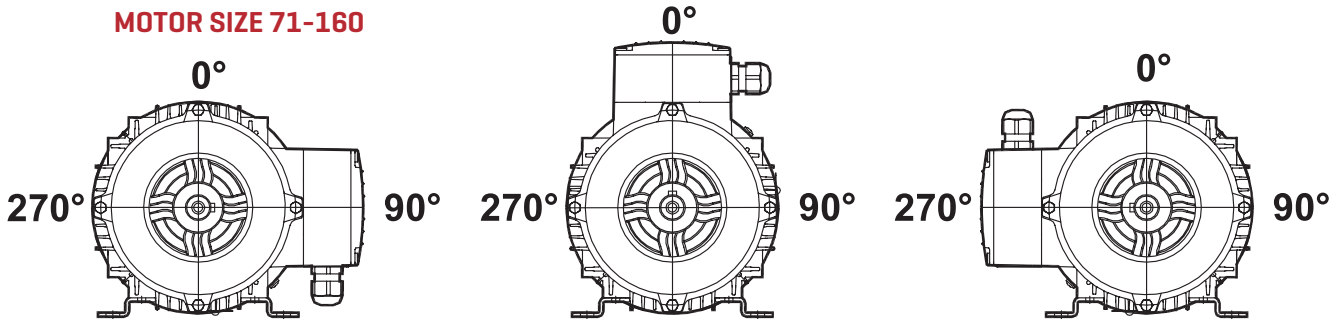

MOTOR SIZE 180-280

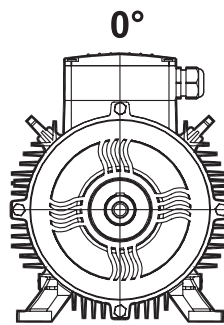

Additionally the housing and end shields are designed symmetrically for all the frame sizes, so that the drive and non-drive side end shields can be replaced and the direction of the rotor shaft group can be changed. By making this end shields and rotor shaft group modifications, the user can have a motor with terminal box is at the non-drive side keeping the distance C according to the standards.

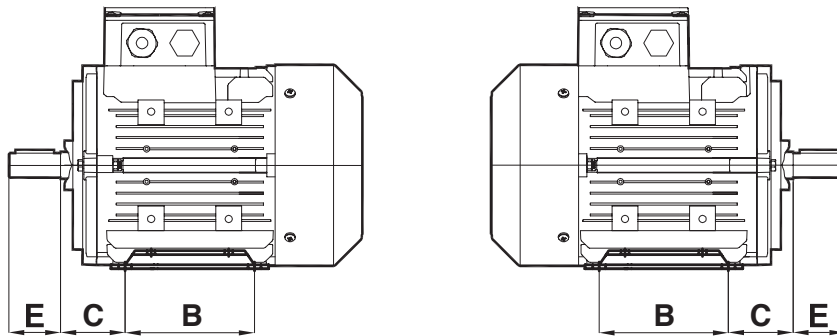

The raw materials that are used in our motors depending on the frame size are listed below.

Frame Size	Housing	End Shield DE	End Shield NDE	Terminal Box & Cover	Feet	Fan Cover	Fan
71	Aluminum	Aluminum	Aluminum	Aluminum	Steel Sheet	Steel Sheet	Plastic
80	Aluminum	Aluminum	Aluminum	Aluminum	Steel Sheet	Steel Sheet	Plastic
90	Aluminum	Aluminum	Aluminum	Aluminum	Steel Sheet	Steel Sheet	Plastic
100	Aluminum	Aluminum	Aluminum	Aluminum	Steel Sheet	Steel Sheet	Plastic
112	Aluminum	Aluminum	Aluminum	Aluminum	Steel Sheet	Steel Sheet	Plastic
132	Aluminum	Aluminum	Aluminum	Aluminum	Steel Sheet	Steel Sheet	Plastic
160	Aluminum	Aluminum	Aluminum	Aluminum	Aluminum	Steel Sheet	Plastic
180	Cast Iron	Cast Iron	Cast Iron	Cast Iron	Cast Iron	Steel Sheet	Plastic
200	Cast Iron	Cast Iron	Cast Iron	Cast Iron	Cast Iron	Steel Sheet	Plastic
225	Cast Iron	Cast Iron	Cast Iron	Cast Iron	Cast Iron	Steel Sheet	Plastic
250	Cast Iron	Cast Iron	Cast Iron	Cast Iron	Cast Iron	Steel Sheet	Plastic
280	Cast Iron	Cast Iron	Cast Iron	Cast Iron	Cast Iron	Steel Sheet	Plastic

Electrical Construction

Standard ELK Motors have insulation Class F while the temperature rise is Class B. This means the motors will have a longer service life and work under hard conditions. Upon the customer's request, Class H insulation motors are manufactured.

Electrical Connections

Cable Gland and Blind Cap														
Frame Size	071	080	090	100	112	132	160	180	200	225	250	280		
Cable Glands	M20x1,5			M25x1,5			2 x M32x1,5		2 x M40x1,5		2 x M50x1,5		2 x M63x1,5	
Blind Cap	M16x1,5			M25x1,5			-		-		-		-	

Terminal Connections													
Frame Size	071	080	090	100	112	132	160	180	200	225	250	280	
Terminal Size	M4			M5			M6			M8		M10	

The motors shall be connected in star or delta according to rated voltage given in their nameplate and the network voltage that they will be connected. For phase to phase 400V supply the motors with 230/400V nameplate values shall be connected in star and the motors with 400/690V nameplates values shall be connected in delta.

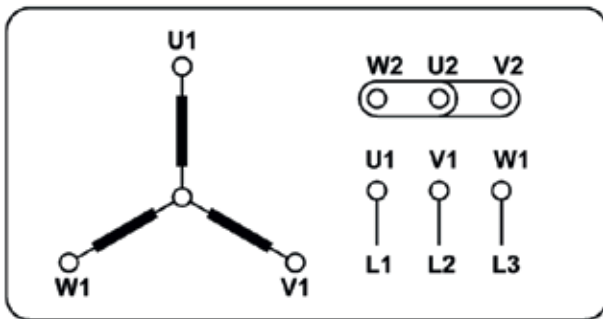

Y Star Connection

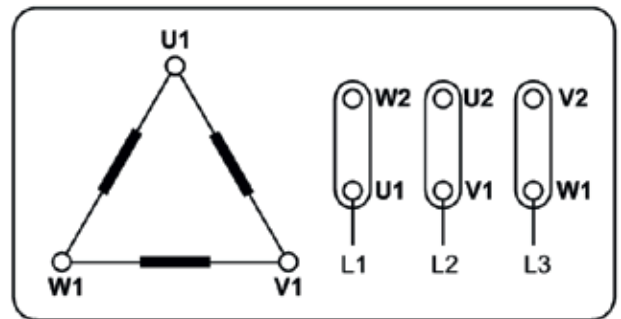

Δ Delta Connection

Motors at 60Hz Network

Standard ELK Motors that have been manufactured for 50 Hz power supply can be used at 60Hz network. The ratios given below indicate changes in the given rated values.

50 Hz Rated Voltage	60 Hz Rated Voltage	Rated Speed	Rated Power	Rated Torque	Rated Current	Starting Torque	Break Down Torque	Starting Current
230V	220V	1.193	1	0.84	0.97	0.77	0.8	0.8
400V	380V	1.193	1	0.84	0.97	0.77	0.8	0.8
400V	440V	1.20	1.16	0.97	0.98	0.87	0.9	0.9

Motors With Variable Speed Drives

Standard ELK Motors are suitable for variable speed drives. The frequency range that the motor can be driven with their fan is given below with blue line. If the motor will be driven in a wider range then a separately driven fan is necessary. By using a separately driven fan, the motors can be driven in the range defined by red line.

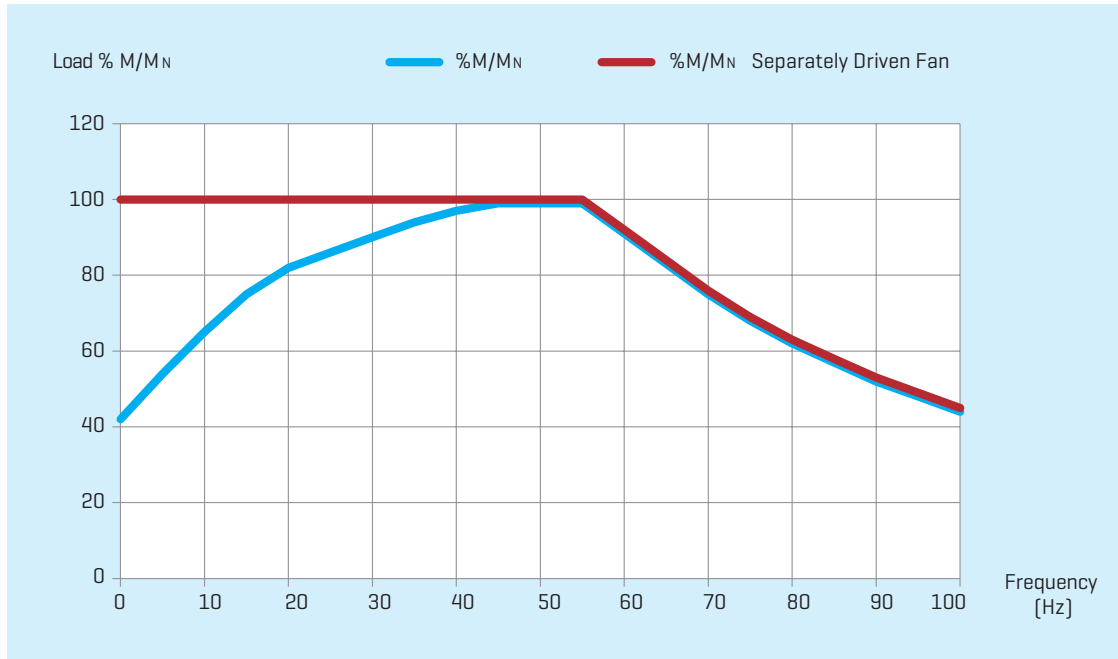

Motors In Several Environmental Conditions

ELK Motors are designed to operate at ambient temperature up to 40°C according to IEC 60034-1. Rated output will change at the % ratings given below for different ambient temperatures.

Ambient Temperature	<30 °C	35 °C	40 °C	45 °C	50 °C	55 °C	60 °C
% Power Ratio	105	102	100	97	93	87	82

Winding Insulation / Temperature Rise Classes

All standard motors in the ELK Motor range have F [155 °C] class electrical insulation system. However, by means of its superior design features, the temperature rise of all standard motors remain within the Class B temperature rise limits when operating under rated conditions. Depending on the safety margin of the temperature rise class provided, our motors can provide 15% higher rated output power with a service factor of 1.15 [SF].

INSULATION CLASS

Maximum Winding Temperature

Tolerance

Limits of Winding Temperature

Ambient Temperature

B 130°C

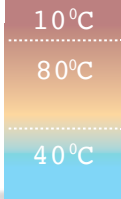

B

Class B insulation system is shown for reference purposes only. Class B insulation system is not used in ELK motors.

F 155°C



F (Standard)

Our standard motors have class F electrical insulation system. The maximum permissible winding temperature at 40°C ambient temperature is 155°C.

H 180°C



H (Optional)

H class insulation is provided on special request. At 40°C ambient temperature, the maximum permissible winding temperature is 180°C

Protection Classes

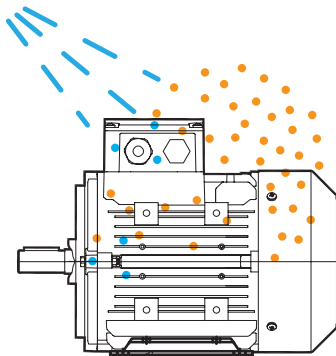

IP55 (Standard)

Limited protection against dust ingress and protected against low pressure water jets from any direction.

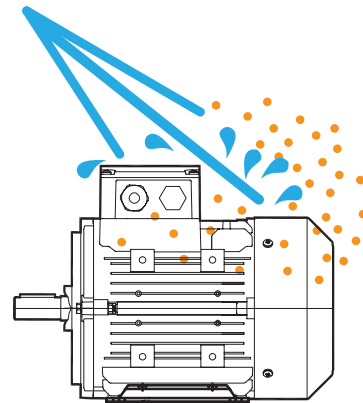

IP56

Limited protection against dust ingress and protected against high pressure water jets from any direction.

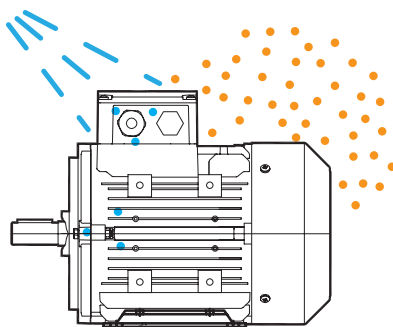

IP65

Totally protected against dust ingress and protected against low pressure water jets from any direction.

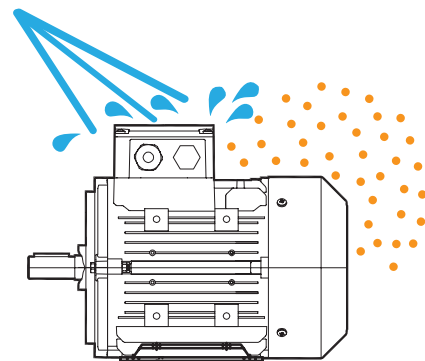

IP66

Totally protected against dust ingress and protected against high pressure water jets from any direction.

Construction Types

ELK Motors are manufactured according to International Mounting Standard IEC 60034-7.

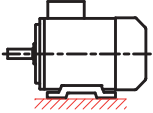
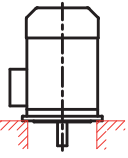
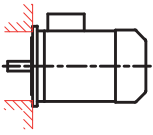
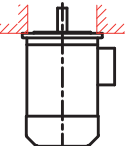
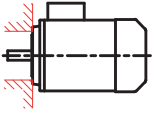
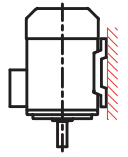
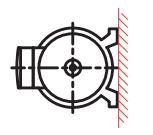
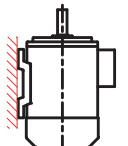
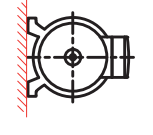
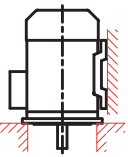
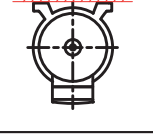
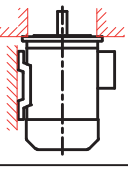
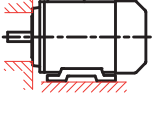
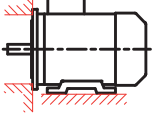
Mounting codes and diagrams according to IEC 60034-7					
Horizontal Mounting Codes			Vertical Mounting Codes		
	I	II		I	II
	IM B3	IM 1001		IM V1	IM 3011
	IM B5	IM 3001		IM V3	IM 3031
	IM B14	IM 3601		IM V5	IM 1011
	IM B7	IM 1061		IM V6	IM 1031
	IM B6	IM 1051		IM V15	IM 2011
	IM B8	IM 1071		IM V35	IM 2031
	IM B34	IM 2101			
	IM B35	IM 2001			

Bearings

Standard ELK Motors are equipped with ball bearings with ZZ shields as listed below, according to frame size. NU-NJ bearings are optional.

Frame Size	Drive End Bearing	Non Drive End Bearing
71	6202 ZZ	6202 ZZ
80	6204 ZZ	6204 ZZ
90	6205 ZZ	6205 ZZ
100	6206 ZZ	6206 ZZ
112	6206 ZZ	6206 ZZ
132	6208 ZZ	6208 ZZ
160	6309 ZZ	6209 ZZ
180	6310 ZZ	6210 ZZ
200	6312 ZZ	6212 ZZ
225	6313 ZZ	6213 ZZ
250	6315 ZZ	6215 ZZ
280	6317	6317

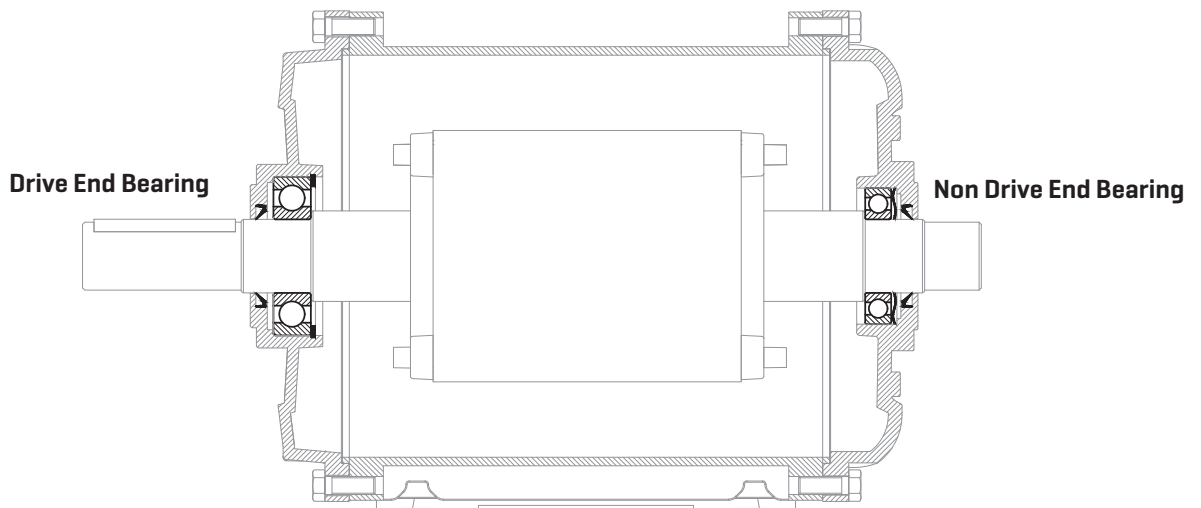

Radial Loads

Radial Load [F_R]:

Radial load can be calculated according to below written formulae.

Calculated radial load must be below permissible radial loads given at tables.

If above, please contact with us.

$$F_R = k \cdot \frac{P}{D \cdot n} \cdot 10^7 \text{ (N)}$$

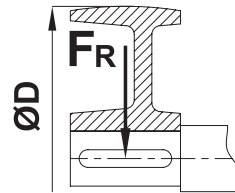

Correction of Permissible Radial Load

If the radial load is applied between points x_0 and x_{max} , the permissible radial load can be corrected with the following formulae.

$$F_{r_x} = F_{r_0} - \frac{x}{E} (F_{r_0} - F_{r_{max}})$$

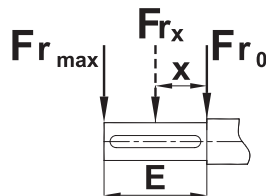

P: Motor Power [kW]

D: Pulley Diameter [mm]

n: Motor speed [rpm]

k: Radial load factor

- Spur Gears, chain drives with low speed = 2,1
- Trigger Belts = 2,5
- V type belts = 5

$F_R < F_{r_x}$: Calculated radial load must be below permissible radial loads given at tables.

F_a: Axial load

F_{r0}: Permissible radial load at shaft spigot.

F_{rmax}: Permissible radial load at shaft end point.

Permissible loads are calculated for L_{h10} 20000 h bearing lifetimes according to ISO 281.

Radial Loads

HORIZONTAL MOUNTING - Permissible Radial Loads
 Mounting Positions IM: B3, B5, B6, B7, B8, B14, B34, B35

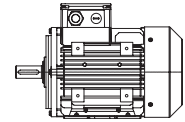

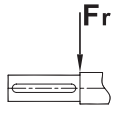
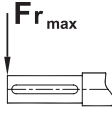
Frame Size	Fa = 0	
		
2 Poles 3000 d/d	Fr_o [N]	Fr_{max} [N]
71	380	340
80	640	550
90	750	660
100	1050	900
112	1050	910
132	1520	1220
160	2800	2300
180	3250	2650
200	4340	3560
225	4950	4000
250	6050	4800
280	6800	5500
4 Poles 1500 d/d	Fr_o [N]	Fr_{max} [N]
71	520	440
80	800	700
90	950	780
100	1300	1050
112	1300	1050
132	1950	1600
160	3540	2825
180	4100	3400
200	5500	4550
225	6200	4900
250	7500	6000
280	8200	7500
6 Poles 1000 d/d	Fr_o [N]	Fr_{max} [N]
71	580	500
80	870	800
90	1090	900
100	1500	1250
112	1500	1250
132	2200	1800
160	4050	3190
180	4720	3830
200	6350	5150
225	7350	5650
250	8950	7200
280	9500	8500

Fa₀ : Permissible axial load

Fr : Radial load

Fr_o : Permissible radial load at shaft spigot.

Fr_{max} : Permissible radial load at shaft end point.

Permissible loads are calculated for L_{h10} 20000 h bearing lifetimes according to ISO 281.

Axial Loads

HORIZONTAL MOUNTING – Permissible Axial Loads
 Mounting Positions IM: B3, B5, B6, B7, B8, B14, B34, B35

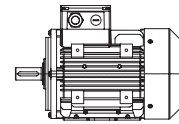

Frame Size	Push			Pull
	Fr = 0	Fr = Fr ₀	Fr = Fr _{max}	Fr = 0
2 Poles 3000 d/d	Fa₀ [N]	Fa₀ [N]	Fa₀ [N]	Fa₀ [N]
71	110	110	110	250
80	190	190	190	395
90	210	210	210	400
100	270	270	270	580
112	270	270	270	580
132	380	380	370	800
160	2280	1060	1020	1670
180	2660	1250	1250	1970
200	3150	1500	1390	2600
225	3850	1850	1760	2750
250	4150	2180	2250	3350
280	5000	2500	2500	4000
4 Poles 1500 d/d	Push			Pull
	Fa₀ [N]	Fa₀ [N]	Fa₀ [N]	Fa₀ [N]
71	110	110	110	360
80	190	190	190	560
90	210	210	210	585
100	300	300	300	830
112	300	300	300	830
132	400	400	400	1200
160	2280	1400	1400	2350
180	3100	1570	1500	2800
200	4400	1770	1770	3810
225	4950	2150	2200	4300
250	6050	2400	2400	4500
280	7200	3000	3000	5500
6 Poles 1000 d/d	Push			Pull
	Fa₀ [N]	Fa₀ [N]	Fa₀ [N]	Fa₀ [N]
71	110	110	110	430
80	190	190	190	700
90	210	210	210	740
100	290	290	290	1020
112	290	290	290	1020
132	380	380	380	1470
160	3050	1540	1520	2900
180	3540	1780	1700	3410
200	4800	2200	2250	4400
225	5050	2580	2800	5200
250	6050	3100	3150	6500
280	7000	3700	3400	7150

Fa₀ : Permissible axial load

Fr : Radial load

Fr₀ : Permissible radial load at shaft spigot.

Fr_{max} : Permissible radial load at shaft end point.

Permissible loads are calculated for L_{h10} 20000 h bearing lifetimes according to ISO 281.

Axial Loads

VERTICAL MOUNTING- Shaft Pointing Upwards – Permissible Axial Loads
 Mounting Positions IM: V3, V6, V19, V35, V37

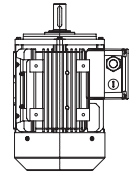

Frame Size	Push			Pull
	Fr = 0	Fr = Fr ₀	Fr = Fr _{max}	Fr = 0
2 Poles 3000 d/d	Fa₀ [N]	Fa₀ [N]	Fa₀ [N]	Fa₀ [N]
71	100	100	100	265
80	170	170	170	425
90	180	180	180	450
100	250	250	250	650
112	250	250	250	660
132	300	300	300	970
160	2080	1060	990	1950
180	2410	1190	1050	2350
200	2900	1265	1265	3000
225	3250	1310	1295	3575
250	3950	1460	1450	4350
280	4500	1600	1500	5250
4 Poles 1500 d/d	Push			Pull
	Fa₀ [N]	Fa₀ [N]	Fa₀ [N]	Fa₀ [N]
71	95	95	95	380
80	160	160	160	600
90	170	170	170	650
100	210	210	210	930
112	210	210	210	950
132	240	240	240	1430
160	2500	1250	1220	2160
180	2900	1400	1370	2570
200	3900	1360	1530	3500
225	4450	1570	1680	4000
250	5400	1870	1910	4300
280	5800	2000	1600	7100
6 Poles 1000 d/d	Push			Pull
	Fa₀ [N]	Fa₀ [N]	Fa₀ [N]	Fa₀ [N]
71	95	95	95	455
80	160	160	160	745
90	170	170	170	800
100	230	230	230	1120
112	210	210	210	1150
132	250	250	250	1690
160	2980	1490	1450	3300
180	3400	1670	1670	3800
200	4250	1850	1860	5100
225	4800	1980	2080	5800
250	5300	2200	2260	6200
280	6300	2200	2050	7500

Fa₀ : Permissible axial load

Fr : Radial load

Fr₀ : Permissible radial load at shaft spigot.

Fr_{max}: Permissible radial load at shaft end point.

Permissible loads are calculated for L_{h10} 20000 h bearing lifetimes according to ISO 281.

Axial Loads

VERTICAL MOUNTING-Shaft Pointing Downwards- Permissible Axial Loads
 Mounting Positions IM: V1, V5, V15, V17, V18

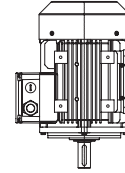

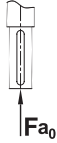
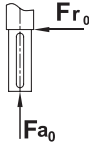
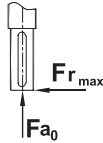
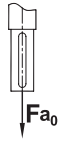
Frame Size	Push			Pull
	Fr = 0	Fr = Fr ₀	Fr = Fr _{max}	Fr = 0
				
2 Poles 3000 d/d	Fa ₀ [N]	Fa ₀ [N]	Fa ₀ [N]	Fa ₀ [N]
71	130	130	130	235
80	220	220	220	385
90	250	250	250	375
100	330	330	330	535
112	340	340	340	520
132	490	550	550	680
160	2600	1550	1500	1500
180	3070	1850	1750	1700
200	3550	2300	2300	2315
225	4250	2680	2670	2630
250	5200	3200	3280	3100
280	6500	3750	3750	3300
4 Poles 1500 d/d	Push			Pull
	Fa ₀ [N]	Fa ₀ [N]	Fa ₀ [N]	Fa ₀ [N]
71	130	130	130	340
80	220	220	220	540
90	260	260	260	545
100	380	370	370	760
112	410	400	400	740
132	580	570	570	1040
160	3500	1910	1840	2100
180	4000	2300	2170	2450
200	4250	2870	2850	2200
225	5000	3350	3380	3740
250	6200	4200	4000	4440
280	8900	4850	4850	4400
6 Poles 1000 d/d	Push			Pull
	Fa ₀ [N]	Fa ₀ [N]	Fa ₀ [N]	Fa ₀ [N]
71	130	130	130	415
80	220	220	220	675
90	250	250	250	700
100	360	360	360	960
112	390	390	390	930
132	560	560	560	1310
160	3100	2130	2120	2650
180	3600	2600	2490	3030
200	5000	3260	3300	4000
225	5550	3710	3810	4650
250	6200	4510	4550	5500
280	7500	5300	5200	5750

Fa₀ : Permissible axial load

Fr : Radial load

Fr₀ : Permissible radial load at shaft spigot.

Fr_{max}: Permissible radial load at shaft end point.

Permissible loads are calculated for L_{h10} 20000 h bearing lifetimes according to ISO 281.



PRODUCT TYPE CODES

PRODUCT TYPE CODES

2 EL 132 M 4 C FC 00 000

2	----->	<p>Motor Efficiency Classes</p> <p>2: IE2 3: IE3 4: IE4</p>
EL	----->	<p>Basic Motor Type</p> <p>EL : Aluminum housing standard motors EG : Cast iron housing standard motors EC : Aluminum housing compact motors ED : Cast iron housing compact motors</p>
132	----->	<p>Frame Size: 71, 80, 90, 100, 112, 132, 160, 180, 200, 225, 250, 280</p> <p>Height of the shaft axis from feet base of motor [mm]</p>
M	----->	<p>Housing Length</p> <p>S : Short M: Medium L : Long</p>
4	----->	<p>Number of Poles</p> <p>2:2 poles 3000 rpm 4:4 poles 1500 rpm 6:6 poles 1000 rpm D: dahlander 4/2 poles constant torque 1500/3000 rpm E: dahlander 4/2 poles constant torque 1500/3000 rpm F: dahlander 8/4 poles constant torque 750/1500 rpm G: dahlander 8/4 poles constant torque 750/1500 rpm S: seperate windings 6/4 poles 1000/1500 rpm T: seperate windings 12/4 poles 500/1500 rpm U: seperate windings 12/2 poles 500/3000 rpm Z: 12 poles 500 rpm</p>
C	----->	<p>Core Length: A, B, C, D, E</p>
FC	----->	<p>Construction Types / Flange Types</p> <p>PD : B3 Foot Mounted FA : B5 Flange FC : B14 Flange FS : Special Flange PA : B35 PC : B34 PS : Foot mounted with special flange Y0..Y9: With flange for gearbox connection PX : Foot mounted without drive end shield XX : Without foot and drive end shield Z0-Z9: Foot mounted Yilmaz type</p>
00	----->	<p>Electrical Specifications</p> <p>AA..ZZ Voltage, Frequency and electrical features</p> <p>2nd digit : Additional electrical features</p> <p>0: Standard motor, basic version A: Motors with thermistor B: Motors with anti-condensation heater C: Motors with thermal switch K: Motors with thermistor anti-condensation heater</p> <p>1st digit: Voltage and Frequency</p> <p>A : 230/400V 50Hz B : 400/690V 50Hz C : 240/415V 50Hz D : 415/720V 50Hz E : 230/400V 60Hz 1,16 increased rated output power F : 400/690V 60Hz 1,16 increased rated output power G : 220V 60Hz H : 290/500V 50Hz I : 220/380V 60Hz 1,16 increased rated output power J : 380/660V 60Hz 1,16 increased rated output power</p>
000	----->	<p>Additional Motor Features</p> <p>000.....999 000 : Standard Motor</p>



The image shows a factory floor with a red metal structure. Several large, grey electric motors are suspended from the ceiling by chains and hooks. In the foreground, a row of similar motors sits on a workbench. In the background, workers in dark clothing are visible, working on the machinery. The overall scene is industrial and brightly lit.

IE2 MOTORS

IE2

Electrical Characteristics

400V 50Hz 3000 rpm

Duty Cycle : S1 [Continuous Operation]
 Insulation Class : F [155°C]
 Temperature Rise : B [80°K]



Voltage [V]	Type	Rated Values								Starting Values		Break Down Torque	Moment of Inertia	B3 Motor Weight	Sound Pressure Level
		Power	Speed	Current	Torque	Power Factor	Efficiency % η			Current	Torque				
		kW	d/d	A	Nm	Cos φ	4/4	3/4	1/2	I _A /I _N	M _A /M _N				
230/400	2EL071M2A	0,37	2790	0,90	1,26	0,80	74,2	74,5	72,5	5,0	2,5	2,8	0,00031	5,5	54
	2EL071M2B	0,55	2790	1,27	1,88	0,82	75,8	77,0	76,0	5,0	2,8	2,9	0,00037	6,3	54
	2EL080M2A	0,75	2850	1,67	2,51	0,83	78,0	79,0	77,5	5,7	2,5	3,0	0,00089	8,7	56
	2EL080M2B	1,10	2850	2,36	3,69	0,84	80,1	81,3	80,7	5,8	2,7	3,1	0,00103	9,7	56
	2EL090S2A	1,50	2880	3,17	4,98	0,83	82,5	82,6	82,0	6,0	2,6	3,3	0,00152	14,1	60
	2EL090L2B	2,20	2860	4,48	7,35	0,85	83,2	85,0	85,0	6,0	2,6	3,1	0,00178	15,5	60
	2EL100L2B	3,00	2890	5,80	9,91	0,88	84,8	85,2	84,7	7,0	2,6	3,4	0,00380	20,8	63
400/690	2EL112M2A	4,00	2910	7,60	13,13	0,88	86,5	87,1	86,8	7,0	2,4	3,6	0,00530	25,7	66
	2EL132S2A	5,50	2935	10,20	17,90	0,88	88,2	88,4	87,6	7,9	2,8	3,9	0,01550	41,0	68
	2EL132S2B	7,50	2925	13,60	24,50	0,90	88,5	88,8	88,6	7,6	2,6	3,9	0,01730	45,2	68
	2EL160M2A	11,00	2940	19,60	35,73	0,90	89,8	90,0	89,0	7,4	2,7	3,6	0,02920	71,4	70
	2EL160M2B	15,00	2935	26,90	48,80	0,89	90,3	91,0	90,7	7,0	2,6	3,5	0,03320	77,0	70
	2EL160L2C	18,50	2935	32,20	60,19	0,91	91,1	91,5	91,0	8,2	2,9	3,8	0,03910	89,0	70
	2EG180M2A	22,00	2955	39,00	71,10	0,89	91,4	91,6	90,6	7,9	2,6	3,6	0,06300	163	71
	2EG200L2A	30,00	2965	52,00	96,63	0,90	92,4	92,7	92,2	8,0	2,9	3,1	0,14600	230	74
	2EG200L2B	37,00	2965	64,00	119,20	0,90	92,7	93,2	93,0	8,4	3,1	3,3	0,16200	240	75
	2EG225M2B	45,00	2970	77,40	144,70	0,90	93,2	93,5	93,0	8,6	2,7	3,7	0,22000	310	75
	2EG250M2B	55,00	2970	94,50	176,80	0,90	93,3	93,6	93,1	7,9	2,7	3,6	0,32800	388	77
	2EG280S2A	75,00	2978	128,0	240,50	0,90	93,8	94,0	93,0	7,9	2,7	3,0	0,70000	510	77
	2EG280M2B	90,00	2980	153,0	288,40	0,90	94,1	94,2	93,1	7,5	2,8	3,2	0,79000	570	77

400V 50Hz 1500 rpm

Duty Cycle : S1 [Continuous Operation]
 Insulation Class : F [155°C]
 Temperature Rise : B [80°K]



Voltage [V]	Type	Rated Values								Starting Values		Break Down Torque	Moment of Inertia	B3 Motor Weight	Sound Pressure Level
		Power	Speed	Current	Torque	Power Factor	Efficiency % η			Current	Torque				
		kW	d/d	A	Nm	Cos φ	4/4	3/4	1/2	I _A /I _N	M _A /M _N				
230/400	2EL071M4B	0,25	1425	0,71	1,68	0,69	74,0	73,5	70,5	4,4	2,0	3,0	0,00067	5,9	46
	2EL071M4C	0,37	1425	1,00	2,47	0,70	76,1	75,5	71,5	4,6	2,0	3,0	0,00082	6,7	46
	2EL080M4B	0,55	1440	1,45	3,65	0,71	77,1	76,7	75,0	5,2	2,0	3,0	0,00175	9,7	50
	2EL080M4C	0,75	1440	1,95	4,97	0,70	79,6	79,2	77,0	5,2	2,0	3,0	0,00200	10,5	50
	2EL090S4B	1,10	1440	2,60	7,30	0,75	81,4	81,4	80,5	5,6	2,2	3,1	0,00281	14,4	52
	2EL090L4C	1,50	1440	3,40	9,95	0,77	82,8	83,0	82,0	6,0	2,3	3,2	0,00356	17,2	52
	2EL100L4B	2,20	1445	4,85	14,60	0,78	84,3	85,3	84,2	6,0	2,4	3,2	0,00634	22,7	54
	2EL100L4C	3,00	1440	6,42	19,89	0,79	85,5	85,7	84,6	6,3	2,4	3,3	0,00775	24,2	54
400/690	2EL112M4C	4,00	1450	8,20	26,35	0,81	86,8	87,4	86,5	6,6	2,5	3,4	0,01220	32,0	58
	2EL132S4B	5,50	1455	11,20	36,10	0,81	87,7	88,6	88,0	6,7	2,6	3,2	0,02520	47,8	62
	2EL132M4C	7,50	1460	15,10	49,00	0,81	88,7	89,0	89,0	7,0	2,7	3,3	0,03060	54,8	62
	2EL160M4B	11,00	1465	21,30	71,70	0,83	89,8	90,3	89,5	6,9	2,4	3,0	0,05800	76,8	65
	2EL160L4C	15,00	1460	28,80	98,12	0,83	90,6	91,3	90,9	6,9	2,6	3,0	0,07000	88,6	65
	2EG180M4B	18,50	1465	34,90	120,60	0,84	91,2	91,5	91,4	6,9	2,5	3,0	0,11100	158	65
	2EG180L4C	22,00	1465	41,40	143,40	0,84	91,6	91,7	91,5	7,1	2,6	3,2	0,12900	174	65
	2EG200L4C	30,00	1475	55,50	194,24	0,85	92,3	93,0	93,2	7,6	3,0	3,1	0,23300	241	65
	2EG225S4B	37,00	1475	66,00	239,50	0,87	93,0	93,8	93,8	7,8	3,0	3,1	0,33900	297	66
	2EG225M4C	45,00	1475	80,00	291,40	0,87	93,1	94,0	94,3	7,8	3,0	3,0	0,38200	333	66
	2EG250M4C	55,00	1478	95,50	355,40	0,89	93,5	94,3	94,4	7,9	3,2	3,0	0,62400	430	68
	2EG280S4B	75,00	1483	130,8	482,97	0,88	94,0	94,5	94,4	7,9	3,0	3,0	1,25000	618	69
	2EG280M4C	90,00	1484	156,0	579,20	0,88	94,2	94,6	94,5	7,9	3,2	3,1	1,40000	648	70

Electrical Characteristics

400V 50Hz 1000 rpm

Duty Cycle : S1 [Continuous Operation]
 Insulation Class : F [155°C]
 Temperature Rise : B [80°K]



Voltage [V]	Type	Rated Values								Starting Values		Break Down Torque	Moment of Inertia	B3 Motor Weight	Sound Pressure Level
		Power	Speed	Current	Torque	Power Factor	Efficiency % η			Current	Torque				
		kW	d/d	A	Nm	Cos φ	4/4	3/4	1/2	I _A /I _N	M _A /M _N				
230/400	2EL071M6B	0,18	920	0,60	1,87	0,67	64,5	63,0	57,0	3,2	1,9	2,3	0,00076	5,9	42
	2EL071M6C	0,25	920	0,78	2,59	0,69	66,5	66,0	61,0	3,3	1,9	2,3	0,00096	6,6	42
	2EL080M6A	0,37	925	1,08	3,82	0,69	71,4	71,5	70,0	4,0	2,0	2,6	0,00176	9,1	45
	2EL080M6B	0,55	932	1,50	5,64	0,72	73,5	74,0	71,0	4,2	2,1	2,6	0,00202	9,9	45
	2EL090S6A	0,75	940	2,00	7,62	0,71	75,9	76,1	73,1	4,1	2,0	2,6	0,00229	13,3	48
	2EL090L6B	1,10	940	2,90	11,18	0,70	78,1	78,3	75,0	4,3	2,1	2,6	0,00354	14,8	48
	2EL100L6A	1,50	950	3,72	15,00	0,73	79,8	80,2	79,5	4,5	2,1	2,6	0,00680	20,2	52
	2EL112M6A	2,20	960	5,32	21,90	0,73	81,8	82,0	81,5	5,3	2,1	2,7	0,01170	25,0	56
400/690	2EL132S6A	3,00	970	6,85	29,60	0,76	83,3	84,0	83,0	5,6	2,0	2,8	0,02610	42,0	60
	2EL132M6B	4,00	970	8,80	39,38	0,77	85,2	85,7	85,3	5,2	2,1	2,6	0,03050	46,0	60
	2EL132M6C	5,50	965	12,00	54,40	0,77	86,0	87,2	87,0	5,7	2,1	2,7	0,03500	51,0	60
	2EL160M6B	7,50	972	16,30	73,68	0,76	87,2	88,1	87,7	5,6	2,4	2,7	0,05700	77,8	63
	2EL160L6D	11,00	970	22,95	108,30	0,78	88,7	90,0	89,9	6,0	2,5	2,9	0,07870	97,8	63
	2EG180L6D	15,00	972	31,00	147,40	0,78	89,7	90,5	90,2	6,2	2,5	2,9	0,13500	175	64
	2EG200L6B	18,50	977	36,50	180,80	0,81	90,4	90,5	90,7	6,3	2,5	2,6	0,30100	205	64
	2EG200L6C	22,00	978	43,00	214,80	0,81	91,1	91,3	91,2	6,2	2,5	2,6	0,33400	215	64
	2EG225S6B	30,00	980	57,60	292,20	0,82	91,7	91,8	90,8	6,6	2,6	2,7	0,52000	314	65
	2EG250M6B	37,00	982	69,60	359,80	0,83	92,3	92,6	92,5	6,8	2,7	2,8	0,68000	395	66
	2EG280S6A	45,00	985	84,50	436,00	0,83	92,7	93,1	92,2	6,8	2,8	2,8	1,15000	490	66
	2EG280M6B	55,00	985	101,5	533,20	0,84	93,1	93,2	92,5	6,9	2,9	2,8	1,45000	545	66

UL approved motors have logo on nameplate



Electrical Characteristics

400V 50Hz 3000 rpm

Duty Cycle : S1 [Continuous Operation]
 Insulation Class : F [155°C]
 Temperature Rise : B [80°K]

Compact IE2

Voltage [V]	Type	Rated Values								Starting Values		Break Down Torque	Moment of Inertia	B3 Motor Weight	Sound Pressure Level
		Power	Speed	Current	Torque	Power Factor	Efficiency % η			Current	Torque				
		kW	d/d	A	Nm	Cos φ	4/4	3/4	1/2	I _A /I _N	M _A /M _N				
230/400	2EC071M2C	0,75	2810	1,70	2,55	0,82	77,7	78,4	76,5	5,0	2,6	3,1	0,00046	7,3	54
	2EC080M2C	1,50	2840	3,18	5,04	0,84	81,3	82,7	81,8	5,6	2,7	3,2	0,00124	11,1	55
	2EC090L2C	3,00	2850	6,10	10,05	0,84	84,6	85,6	85,0	6,2	2,6	3,3	0,00221	17,3	60
400/690	2EC100L2C	4,00	2875	7,75	13,29	0,87	85,8	86,8	86,2	6,5	2,7	3,5	0,00450	23,5	63
	2EC112M2C	5,50	2905	10,35	18,08	0,88	87,0	87,8	87,5	7,3	2,6	3,5	0,00620	29,5	66
	2EC132S2C	11,00	2920	19,73	35,97	0,90	89,4	90,5	90,6	8,1	2,6	3,6	0,02100	52,0	68
	2EC160L2D	22,00	2940	38,40	71,50	0,91	91,5	91,8	91,4	8,3	3,1	3,9	0,07000	103	70
	2ED180M2B	30,00	2950	52,70	97,10	0,89	92,2	92,7	92,3	8,2	2,9	3,8	0,08200	180	71
	2ED200L2C	45,00	2960	77,80	145,20	0,90	92,9	93,2	93,0	8,1	2,7	2,9	0,17500	273	74
	2ED225M2C	55,00	2965	94,70	177,20	0,90	93,2	93,3	93,3	7,8	2,7	2,9	0,25400	382	75
	2ED250M2D	75,00	2970	128,0	241,20	0,90	93,8	93,9	93,5	7,0	2,3	2,5	0,42000	449	77
	2ED280M2D	110,00	2975	187,00	353,10	0,90	94,3	94,5	94,2	8,0	2,6	3,2	0,95000	660	78

400V 50Hz 1500 rpm

Duty Cycle : S1 [Continuous Operation]
 Insulation Class : F [155°C]
 Temperature Rise : B [80°K]

Compact IE2

Voltage [V]	Type	Rated Values								Starting Values		Break Down Torque	Moment of Inertia	B3 Motor Weight	Sound Pressure Level
		Power	Speed	Current	Torque	Power Factor	Efficiency % η			Current	Torque				
		kW	d/d	A	Nm	Cos φ	4/4	3/4	1/2	I _A /I _N	M _A /M _N				
230/400	2EC071M4D	0,55	1405	1,45	3,74	0,72	77,1	77,5	75,0	4,3	2,3	2,5	0,00093	7,7	46
	2EC080M4D	1,10	1430	2,64	7,32	0,74	81,4	79,3	77,0	5,0	2,2	2,9	0,00227	11,9	51
	2EC090L4D	2,20	1430	4,95	14,69	0,76	84,3	83,7	81,0	5,5	2,6	3,0	0,00410	18,4	52
	2EC100L4D	4,00	1430	8,25	26,71	0,81	86,6	87,1	86,0	5,9	2,4	3,1	0,00890	27,1	54
400/690	2EC112M4D	5,50	1440	11,06	36,47	0,83	87,7	88,5	87,5	6,5	2,4	3,1	0,01430	34,5	59
	2EC132M4E	11,00	1445	21,35	72,69	0,83	89,8	90,1	89,3	7,2	2,8	3,2	0,03510	63,2	62
	2EC160L4E	18,50	1450	35,30	121,80	0,83	91,2	91,8	91,5	6,6	2,7	3,2	0,08600	104	64
	2ED180L4D	30,00	1460	56,70	196,23	0,83	92,3	92,8	92,8	6,8	2,8	3,0	0,14700	189	65
	2ED200L4D	37,00	1470	66,20	240,37	0,87	92,7	93,5	93,6	7,6	3,0	3,2	0,28400	263	66
	2ED225M4D	55,00	1470	96,40	357,30	0,88	93,5	93,7	93,9	6,9	2,8	2,9	0,44100	355	68
	2ED250M4D	75,00	1475	129,6	485,60	0,89	94,0	94,9	95,2	8,0	3,2	2,9	0,73400	474	69
	2ED280M4D	110,00	1485	189,00	707,40	0,89	94,5	94,8	94,7	8,0	3,2	3,0	1,50000	670	70

elkmotor.com.tr







IE3 MOTORS

IE3

Electrical Characteristics

400V 50Hz 3000 rpm

Duty Cycle : S1 [Continuous Operation]
 Insulation Class : F [155°C]
 Temperature Rise : B [80°K]



Voltage [V]	Type	Rated Values								Starting Values		Break Down Torque	Moment of Inertia	B3 Motor Weight	Sound Pressure Level
		Power	Speed	Current	Torque	Power Factor	Efficiency % η			Current	Torque				
		kW	d/d	A	Nm	Cos φ	4/4	3/4	1/2	I _A /I _N	M _A /M _N				
230/400	3EL071M2B	0,37	2830	0,86	1,25	0,81	76,6	77,0	75,0	6,0	2,8	3,0	0,00037	6,2	53
	3EL071M2C	0,55	2830	1,19	1,86	0,84	79,4	80,2	78,8	6,1	2,9	3,3	0,00046	7,2	53
	3EL080M2B	0,75	2880	1,59	2,49	0,84	80,7	82,0	81,5	6,7	3,0	3,6	0,00103	9,6	54
	3EL080M2C	1,10	2880	2,26	3,64	0,85	82,7	83,0	82,4	6,8	3,1	3,8	0,00124	10,9	54
	3EL090S2B	1,50	2900	2,97	4,94	0,86	84,8	85,4	84,2	7,6	3,1	3,9	0,00178	15,6	59
	3EL090L2C	2,20	2900	4,25	7,24	0,87	85,9	86,8	86,1	7,2	3,0	3,8	0,00221	17,0	59
	3EL100L2C	3,00	2910	5,58	9,85	0,89	87,1	87,6	86,9	7,9	3,0	4,1	0,00450	23,3	62
400/690	3EL112M2C	4,00	2915	7,28	13,10	0,90	88,1	88,8	88,2	7,5	2,6	3,9	0,00620	29,1	65
	3EL132S2B	5,50	2945	9,90	17,83	0,90	89,2	89,0	88,6	8,9	2,9	3,9	0,01730	44,4	67
	3EL132S2C	7,50	2945	13,20	24,32	0,91	90,1	90,5	89,7	8,4	2,6	4,0	0,02100	51,5	67
	3EL160M2B	11,00	2950	19,70	35,60	0,88	91,2	91,0	90,5	8,0	2,6	3,9	0,03320	79,7	69
	3EL160M2C	15,00	2950	25,90	48,55	0,91	91,9	92,1	91,6	8,9	3,1	4,2	0,03910	86,0	69
	3EL160L2D	18,50	2945	31,70	60,00	0,91	92,4	92,7	92,3	8,9	3,1	4,2	0,04410	96,8	69
	3EG180M2B	22,00	2957	38,10	71,05	0,90	92,7	92,9	92,0	8,6	2,6	3,9	0,06300	178	70
	3EG200L2B	30,00	2970	52,00	96,46	0,89	93,6	93,8	93,6	8,9	3,2	3,5	0,16200	245	72
	3EG200L2C	37,00	2970	62,60	119,00	0,91	93,7	93,8	93,4	9,3	3,2	3,4	0,17500	270	72
	3EG225M2C	45,00	2975	75,60	144,40	0,91	94,3	94,6	94,0	9,8	3,5	3,9	0,25400	335	74
	3EG250M2C	55,00	2970	93,30	176,90	0,90	94,4	94,8	94,5	8,9	3,3	3,4	0,38000	422	75
	3EG280S2B	75,00	2980	127,0	240,35	0,90	94,7	94,7	94,0	7,5	2,7	3,2	0,79000	560	76
	3EG280M2C	90,00	2985	150,0	287,94	0,91	95,0	95,1	94,5	7,6	2,7	3,1	0,90000	630	76

400V 50Hz 1500 rpm

Duty Cycle : S1 [Continuous Operation]
 Insulation Class : F [155°C]
 Temperature Rise : B [80°K]



Voltage [V]	Type	Rated Values								Starting Values		Break Down Torque	Moment of Inertia	B3 Motor Weight	Sound Pressure Level
		Power	Speed	Current	Torque	Power Factor	Efficiency % η			Current	Torque				
		kW	d/d	A	Nm	Cos φ	4/4	3/4	1/2	I _A /I _N	M _A /M _N				
230/400	3EL071M4C	0,25	1435	0,67	1,66	0,71	76,0	75,4	71,5	5,4	2,2	3,0	0,00082	6,8	45
	3EL071M4D	0,37	1435	0,97	2,46	0,70	78,5	78,2	75,0	5,5	2,2	3,1	0,00093	7,5	45
	3EL080M4C	0,55	1450	1,34	3,62	0,73	80,8	80,4	77,0	5,9	2,1	3,1	0,00200	10,5	50
	3EL080M4D	0,75	1450	1,77	4,94	0,74	82,5	82,3	80,0	6,2	2,5	3,4	0,00227	11,6	50
	3EL090S4C	1,10	1450	2,46	7,25	0,76	84,5	84,3	82,0	7,0	2,6	3,6	0,00355	16,3	51
	3EL090L4D	1,50	1450	3,30	9,88	0,77	85,3	85,2	83,0	7,2	2,8	3,8	0,00410	18,0	51
	3EL100L4C	2,20	1450	4,65	14,49	0,79	86,7	87,2	86,0	7,2	2,8	3,6	0,00780	24,4	53
	3EL100L4D	3,00	1450	6,26	19,76	0,79	87,7	88,0	87,0	7,2	2,8	3,6	0,00890	26,7	53
400/690	3EL112M4D	4,00	1460	8,05	26,16	0,81	88,6	88,4	87,5	7,4	2,8	3,8	0,01430	33,9	58
	3EL132S4C	5,50	1460	10,65	36,00	0,83	89,6	90,2	90,0	7,4	2,8	3,4	0,03060	53,4	61
	3EL132M4D	7,50	1465	14,40	48,90	0,83	90,4	90,4	89,4	7,9	3,0	3,8	0,03420	59,5	61
	3EL160M4C	11,00	1470	21,00	71,46	0,83	91,5	92,1	91,7	7,6	2,8	3,3	0,07010	89,2	63
	3EL160L4D	15,00	1470	28,70	97,45	0,82	92,1	92,4	91,9	7,8	2,8	3,6	0,08600	97,5	63
	3EG180M4C	18,50	1475	35,00	119,80	0,82	92,6	93,2	92,9	7,7	3,0	3,3	0,12900	173	64
	3EG180L4D	22,00	1470	41,40	142,92	0,82	93,0	93,7	93,7	8,0	3,0	3,4	0,14700	187	64
	3EG200L4D	30,00	1475	54,50	194,20	0,85	93,6	94,1	94,0	8,0	3,0	3,4	0,28400	258	65
	3EG225S4C	37,00	1478	65,70	239,00	0,87	93,9	94,5	94,5	8,3	3,2	3,3	0,38200	320	66
	3EG225M4D	45,00	1477	80,00	290,90	0,86	94,2	94,7	94,7	8,6	3,3	3,2	0,44100	352	67
	3EG250M4D	55,00	1482	95,30	354,40	0,88	94,6	95,1	95,2	8,7	3,3	3,2	0,73400	470	68
	3EG280S4C	75,00	1485	129,50	482,30	0,88	95,0	95,3	95,1	7,9	3,0	3,2	1,40000	646	69
3EG280M4D	90,00	1485	155,50	578,80	0,88	95,2	95,7	95,7	7,9	3,1	3,2	1,50000	670	70	

Electrical Characteristics

400V 50Hz 1000 rpm

Duty Cycle : S1 [Continuous Operation]
 Insulation Class : F [155°C]
 Temperature Rise : B [80°K]

IE3

Voltage [V]	Type	Rated Values								Starting Values		Break Down Torque	Moment of Inertia	B3 Motor Weight	Sound Pressure Level
		Power	Speed	Current	Torque	Power Factor	Efficiency % η			Current	Torque				
		kW	d/d	A	Nm	cos φ	4/4	3/4	1/2	I _A /I _N	M _A /M _N				
230/400	3EL071M6C	0,18	930	0,55	1,85	0,69	68,0	67,4	62,6	3,6	2,0	2,4	0,00096	6,7	41
	3EL071M6D	0,25	930	0,77	2,57	0,67	70,0	69,7	66,0	3,6	2,2	2,5	0,00116	7,5	41
	3EL080M6B	0,37	930	1,03	3,80	0,70	74,0	73,8	70,0	4,4	2,1	2,6	0,00202	9,8	43
	3EL080M6C	0,55	935	1,47	5,62	0,70	77,2	77,3	74,4	4,3	2,2	2,7	0,00228	10,6	43
	3EL090S6B	0,75	945	1,96	7,58	0,70	78,9	79,2	77,6	4,7	2,2	2,7	0,00354	14,6	46
	3EL090L6C	1,10	940	2,75	11,20	0,71	81,0	80,8	79,4	5,0	2,2	2,7	0,00428	17,0	46
	3EL100L6B	1,50	955	3,50	15,00	0,75	82,5	82,7	81,4	5,3	2,1	2,8	0,00820	22,5	50
	3EL112M6B	2,20	960	4,95	21,90	0,76	84,3	84,5	83,5	5,5	2,2	3,0	0,01320	27,2	56
400/690	3EL132S6B	3,00	970	6,55	29,40	0,77	85,6	85,5	84,5	6,2	2,1	3,0	0,03050	46,5	58
	3EL132M6C	4,00	970	8,52	39,40	0,78	86,8	87,0	85,5	6,2	2,2	3,0	0,03500	51,0	58
	3EL132M6D	5,50	965	11,55	54,40	0,78	88,0	88,9	88,5	6,2	2,2	3,0	0,03940	56,0	58
	3EL160M6D	7,50	972	15,55	73,68	0,78	89,1	89,4	88,4	6,3	2,6	3,0	0,07870	96,0	61
	3EL160L6E	11,00	972	22,90	108,07	0,77	90,3	90,9	90,5	6,6	2,9	3,3	0,08580	104	62
	3EG180L6E	15,00	975	30,80	146,92	0,77	91,2	91,6	91,0	6,7	2,9	3,1	0,15300	187	63
	3EG200L6C	18,50	977	36,40	180,80	0,80	91,7	91,8	91,8	6,1	2,6	2,6	0,36100	225	64
	3EG200L6D	22,00	978	42,50	214,80	0,81	92,2	92,9	93,0	6,2	2,6	2,7	0,39400	245	64
	3EG225S6C	30,00	985	57,60	290,80	0,81	92,9	92,9	92,6	6,6	2,6	2,7	0,60000	326	65
	3EG250M6C	37,00	988	68,80	357,60	0,83	93,4	93,6	93,5	6,8	2,7	2,8	0,82000	432	65
	3EG280S6B	45,00	989	82,50	434,50	0,84	93,7	93,9	93,2	6,8	2,9	2,8	1,45000	540	65
	3EG280M6C	55,00	989	100,40	531,00	0,84	94,1	94,4	93,5	6,9	2,9	2,9	1,65000	575	65

UL approved motors have logo on nameplate





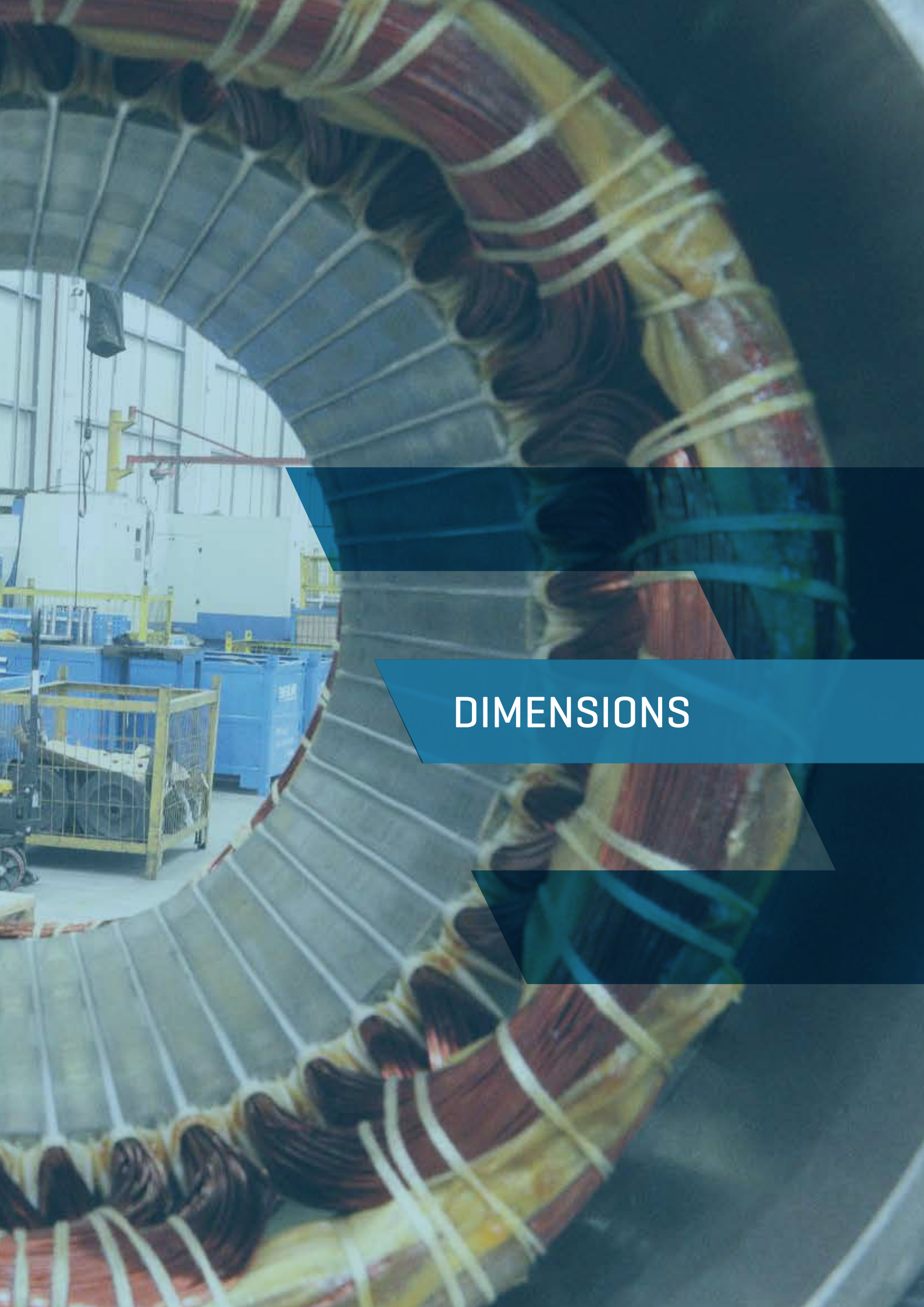

DIMENSIONS

B3 Construction Type

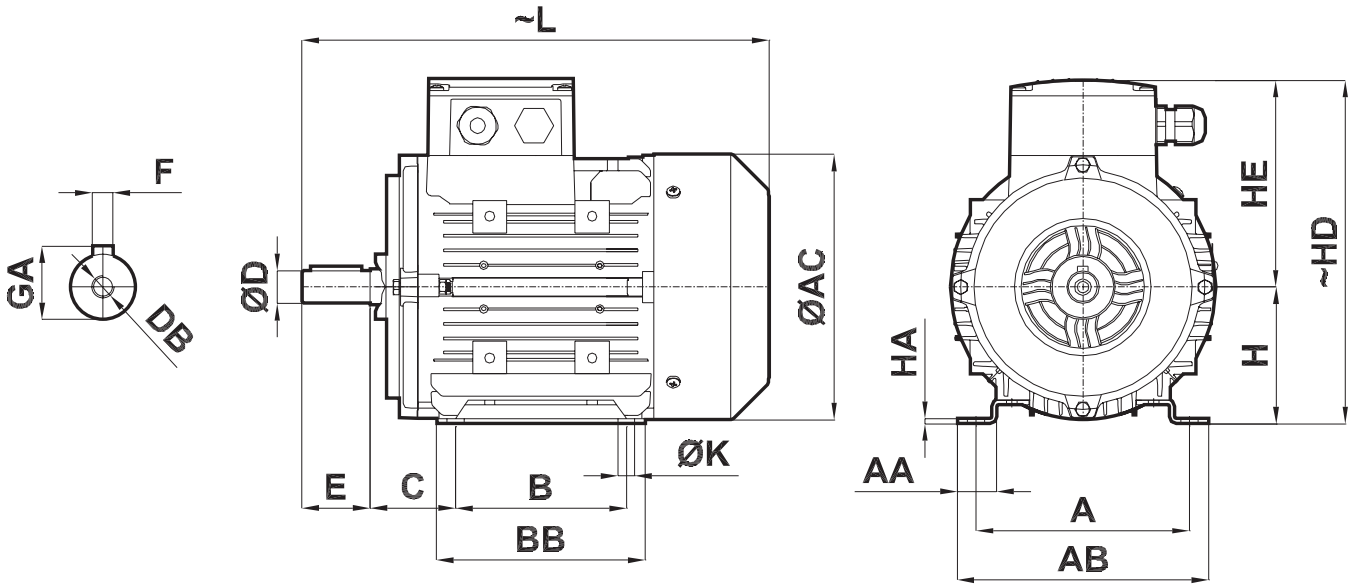

Frame Size	Number of Poles	D ^[1]	E	L	AC	H ^[2]	HE	HD	F	GA	DB	C	ØK	B	BB	HA	AA	A	AB
071	2-4-6-8	14	30	244	137	71	112	183	5	16	M5	45	7	90	110	3	19	112	128
080	2-4-6-8	19	40	274	155	80	123	203	6	21,5	M6	50	10	100	122	3	25	125	148
090S	2-4-6-8	24	50	325	176	90	132	222	8	27	M8	56	10	100	151	4	27	140	167
090L	2-4-6-8	24	50	325	176	90	132	222	8	27	M8	56	10	125	151	4	27	140	167
100	2-4-6-8	28	60	370,5	193	100	149	249	8	31	M10	63	12	140	170	4	31	160	192
112	2-4-6-8	28	60	390	215	112	161	273	8	31	M10	70	12	140	177	4	36	190	217
132S	2-4-6-8	38	80	495	257	132	181	313	10	41	M12	89	12	140	212	5	34	216	254
132M	2-4-6-8	38	80	495	257	132	181	313	10	41	M12	89	12	178	212	5	34	216	254
160M	2-4-6-8	42	110	605	316	160	224	384	12	45	M16	108	14,5	210	323	15	49,5	254	295
160L	2-4-6-8	42	110	605	316	160	224	384	12	45	M16	108	14,5	254	323	15	49,5	254	295
180M	2-4-6-8	48	110	697	348	180	250	430	14	51,5	M16	121	14,5	241	319	15	50	279	326
180L	2-4-6-8	48	110	697	348	180	250	430	14	51,5	M16	121	14,5	279	319	15	50	279	326
200	2-4-6-8	55	110	740	396	200	287	487	16	59	M20	133	18,5	305	350	18	62,5	318	381
225S	4-6-8	60	140	825	438	225	315,5	540,5	18	64	M20	149	18,5	286	370	20	70	356	428
	2	55	110	795					16	59									
225M	4-6-8	60	140	825	438	225	315,5	540,5	18	64	M20	149	18,5	311	370	20	70	356	428
	2	55	110	795					16	59									
250M	4-6-8	65	140	896	481	250	335	585	18	69	M20	168	24	349	420	32,5	80	406	490
	2	60							64										
280M	4-6-8	75	140	1019,5	547	280	402	682	20	79,5	M20	190	24	419	500	36	121	457	558
	2	65							18	69									

[1] Tolerance "j6" up to 28mm, "k6" from 28 to 48mm, "m6" over 48mm TS EN 50347

[2] Tolerance "-0.5mm" TS EN 50347

B5- B35 Construction Types

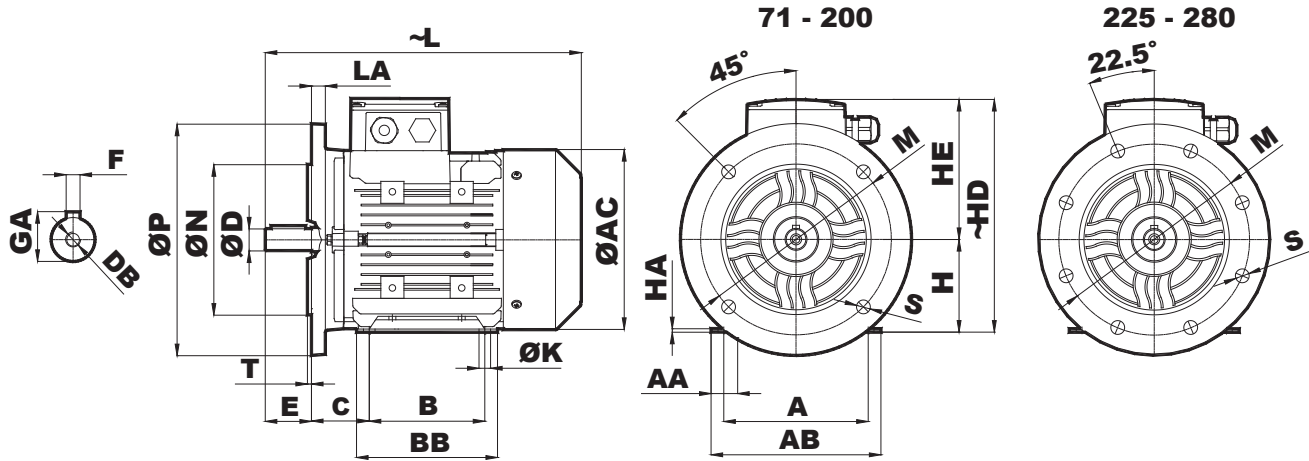

Frame Size	Number of Poles	D ^[1]	E	N ^[2]	P	T	LA	L	AC	S	M	H ^[3]	HE	HD	F	GA	DB	C	ØK	B	BB	HA	AA	A	AB
071	2-4-6-8	14	30	110	160	3,5	8	244	137	10	130	71	112	183	5	16	M5	45	7	90	110	3	19	112	128
080	2-4-6-8	19	40	130	200	3,5	12	274	155	12	165	80	123	203	6	21,5	M6	50	10	100	122	3	25	125	148
090S	2-4-6-8	24	50	130	200	3,5	12	325	176	12	165	90	132	222	8	27	M8	56	10	100	151	4	27	140	167
090L	2-4-6-8	24	50	130	200	3,5	12	325	176	12	165	90	132	222	8	27	M8	56	10	125	151	4	27	140	167
100	2-4-6-8	28	60	180	250	4	15	370,5	193	14,5	215	100	149	249	8	31	M10	63	12	140	170	4	31	160	192
112	2-4-6-8	28	60	180	250	4	15	390	215	14,5	215	112	161	273	8	31	M10	70	12	140	177	4	36	190	217
132S	2-4-6-8	38	80	230	300	4	20	495	257	14,5	265	132	181	313	10	41	M12	89	12	140	212	5	34	216	254
132M	2-4-6-8	38	80	230	300	4	20	495	257	14,5	265	132	181	313	10	41	M12	89	12	178	212	5	34	216	254
160M	2-4-6-8	42	110	250	350	5	20	605	316	18,5	300	160	224	384	12	45	M16	108	14,5	210	323	15	49,5	254	295
160L	2-4-6-8	42	110	250	350	5	20	605	316	18,5	300	160	224	384	12	45	M16	108	14,5	254	323	15	49,5	254	295
180M	2-4-6-8	48	110	250	350	5	14	697	348	18,5	300	180	250	430	14	51,5	M16	121	14,5	241	319	15	50	279	326
180L	2-4-6-8	48	110	250	350	5	14	697	348	18,5	300	180	250	430	14	51,5	M16	121	14,5	279	319	15	50	279	326
200	2-4-6-8	55	110	300	400	5	14	740	396	18,5	350	200	287	487	16	59	M20	133	18,5	305	350	18	62,5	318	381
225S	4-6-8	60	140	350	450	5	20	825	438	18,5	400	225	315,5	540,5	18	64	M20	149	18,5	286	370	20	70	356	428
	2	55	110					795																	
225M	4-6-8	60	140	350	450	5	20	825	438	18,5	400	225	315,5	540,5	18	64	M20	149	18,5	311	370	20	70	356	428
	2	55	110					795																	
250M	4-6-8	65	140	450	550	5	20	896	481	18,5	500	250	335	585	18	69	M20	168	24	349	420	32,5	80	406	490
	2	60														64									
280M	4-6-8	75	140	450	550	5	20	1019,5	547	18,5	500	280	402	682	20	79,5	M20	190	24	419	500	36	121	457	558
	2	65														18									

[1] Tolerance "j6" up to 28mm, "k6" from 28 to 48mm, "m6" over 48mm TS EN 50347

[2] Tolerance "j6" up to 250mm, "h6" over 250mm TS EN 50347

[3] Tolerance "-0.5mm" TS EN 50347

B14- B34 Construction Types

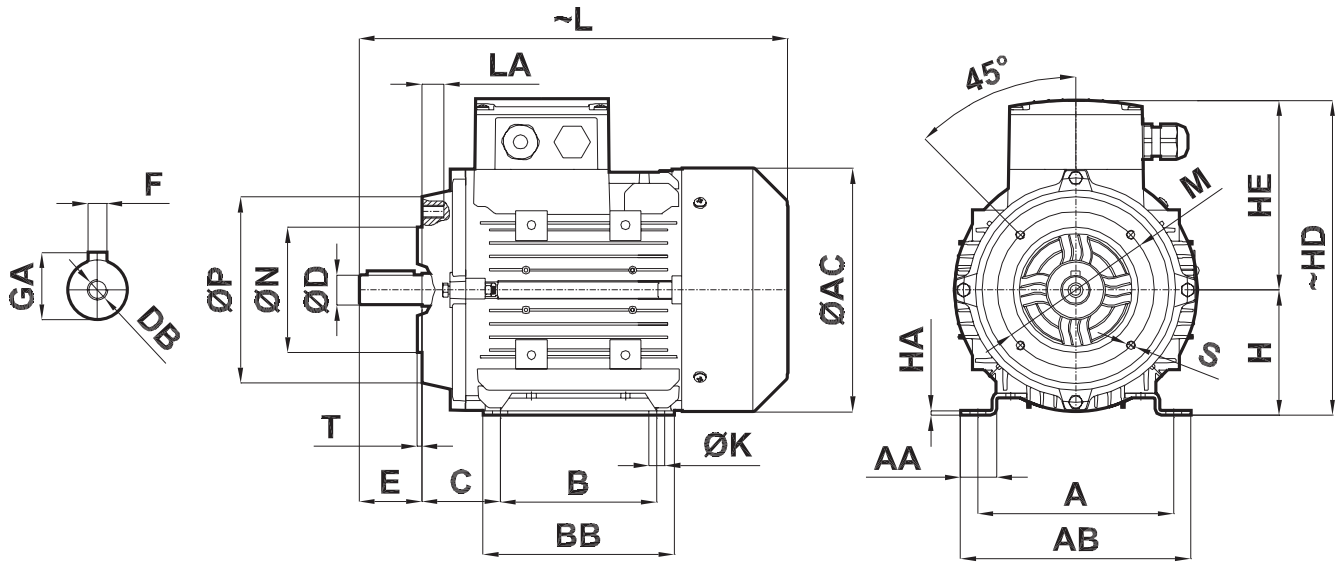

Frame Size	Number of Poles	^[1] D	^[2] N	P	E	T	LA	L	AC	S	M	^[3] H	HE	HD	F	GA	DB	C	ØK	B	BB	HA	AA	A	AB
071	2-4-6-8	14	70	105	30	2,5	12	244	137	M6	85	71	112	183	5	16	M5	45	7	90	110	3	19	112	128
080	2-4-6-8	19	80	118,5	40	3	12	274	155	M6	100	80	123	203	6	21,5	M6	50	10	100	122	3	25	125	148
090S	2-4-6-8	24	95	136,5	50	3	15	325	176	M8	115	90	132	222	8	27	M8	56	10	100	151	4	27	140	167
090L	2-4-6-8	24	95	136,5	50	3	15	325	176	M8	115	90	132	222	8	27	M8	56	10	125	151	4	27	140	167
100	2-4-6-8	28	110	159,5	60	3,5	17	371	193	M8	130	100	149	249	8	31	M10	63	12	140	170	4	31	160	192
112	2-4-6-8	28	110	159,5	60	3,5	17	390	215	M8	130	112	161	273	8	31	M10	70	12	140	177	4	36	190	217
132S	2-4-6-8	38	130	200	80	3,5	20	495	257	M10	165	132	181	313	10	41	M12	89	12	140	212	5	34	216	254
132M	2-4-6-8	38	130	200	80	3,5	20	495	257	M10	165	132	181	313	10	41	M12	89	12	178	212	5	34	216	254
160M	2-4-6-8	42	180	250	110	4	28	605	316	M12	215	160	224	384	12	45	M16	108	14,5	210	323	15	49,5	254	295
160L	2-4-6-8	42	180	250	110	4	28	605	316	M12	215	160	224	384	12	45	M16	108	14,5	254	323	15	49,5	254	295

[1] Tolerance "j6" up to 28mm, "k6" over 28mm TS EN 50347

[2] Tolerance "j6" TS EN 50347

[3] Tolerance "-0.5mm" TS EN 50347

ADDITIONAL INFORMATION



Nameplate Description

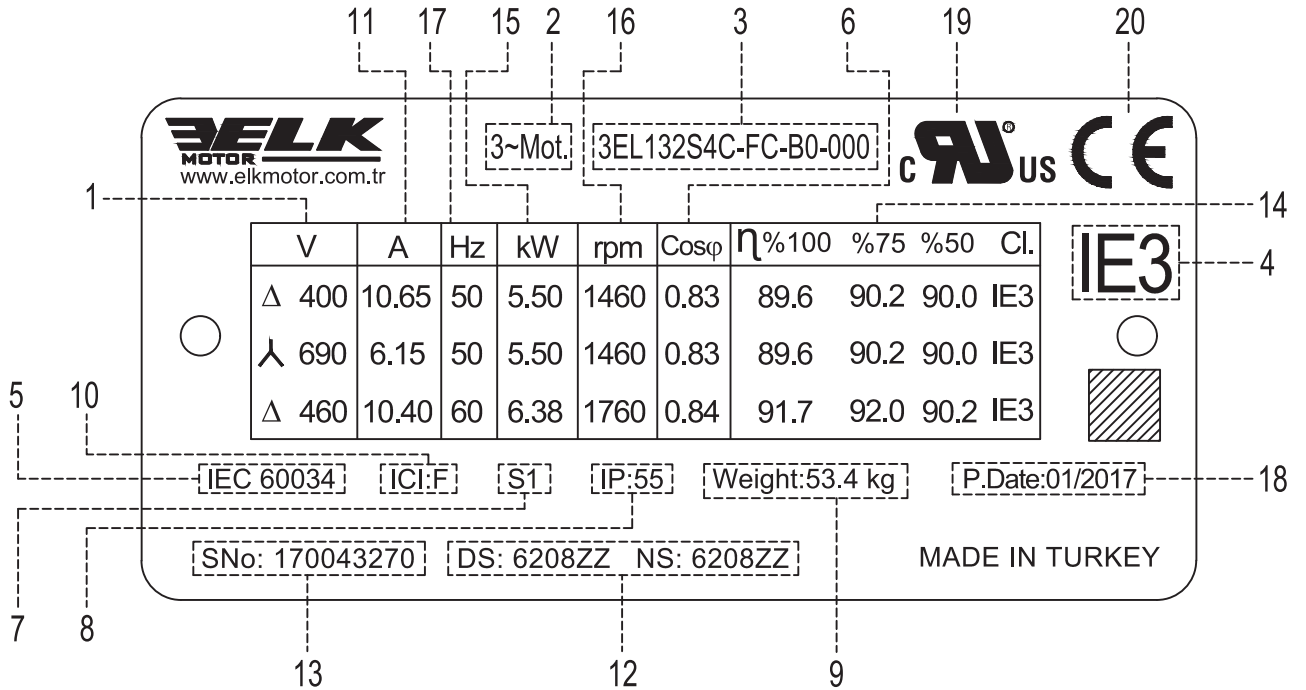

1. Rated Voltage	11. Rated Current
2. Motor Type: 3 Phase Asynchronous	12. Bearing Type
3. Motor Code	13. Serial Number
4. Efficiency Class [IEC 60034-30]	14. Efficiency
5. Manufacture Standard	15. Output Power
6. Power Factor	16. Speed
7. Duty Cycle	17. Frequency
8. Protection Class	18. Production Date
9. Motor Weight	19. UL Logo
10. Insulation Class	20. CE Mark



The nameplate shows the identification, and the most important technical data. The nameplate also defines the limits of proper usage, and manufacturing year of the motors. The first two digits in the serial number, shows the manufacturing year. For example, 17XXXXXXX shows that the product is manufactured in 2017.

Spare Parts

2EL, 3EL, 2EC Series motors consist of the following main parts;

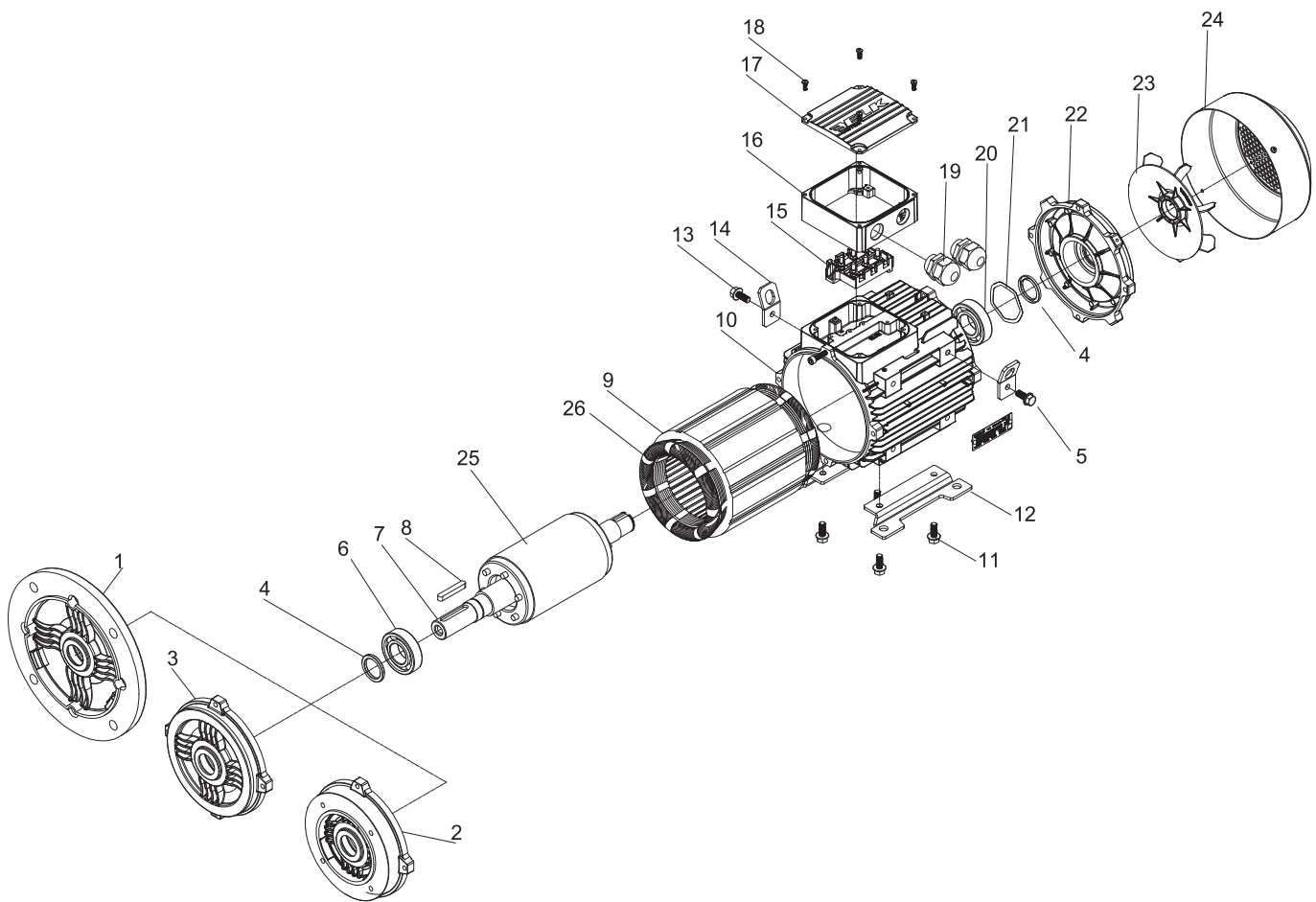

1. Flange B5

2. Flange B14

3. End Shield [DE]

4. Shaft sealing

5. Screw

6. Bearing

7. Shaft

8. Key

9. Stator Core

10. Housing

11. Screw

12. Mounting foot

13. Screw

14. Lifting Lug

15. Terminal

16. Terminal Box

17. Terminal Box Cover

18. Bolt

19. Cable Gland

20. Bearing

21. Spring Washer

22. End Shield [NDE]

23. Fan

24. Fan cover

25. Squirrel cage rotor

26. Winding

When ordering spare parts, the motor serial number, full type designation, and product code, as stated on the nameplate, must be specified. For field service, spare parts and additional information, please contact with us.

PTC Thermistor and Thermal Switch

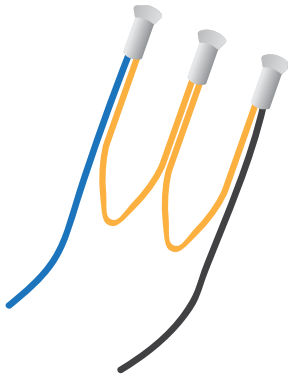

PTC Thermistor

If the motor is exposed to excessive load, the internal resistance of the thermistor attached to the motor windings increases due to the heating of the motor windings and opens the circuit when the insulation class limit value is reached. This prevents the winding from being damaged by cutting off the current in the windings. Only can be used with an electronic circuit.

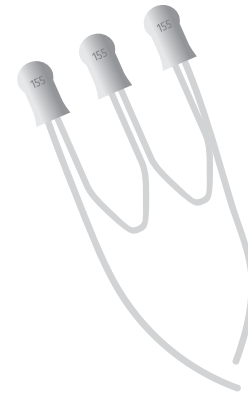

Thermal Switch

When the motor is overloaded winding temperature exceeds the insulation class limit value, and the thermal switch assembled to the winding opens the circuit. In many applications, thermal switch can be connected in series to the main contactor coil.

Depending on the opening of the thermal switch, the main contactor is released and damage to the motor is prevented

Anti-Condensation Heater and Drain Hole

Water condensation inside the motor can occur in high humidity environments. To prevent this, heaters anti-condensation heaters are assembled to the motor windings to maintain a certain temperature.

In addition, drain holes are opened to prevent water from accumulating in the motor body in the event of water condensation inside the motor.

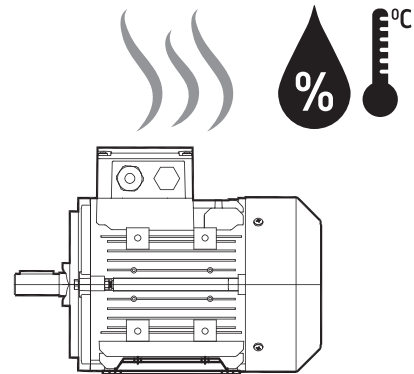

Non Drive End Shaft Extension and Canopy



Non Drive End Shaft Extension

Non drive end shaft is used when it is desired to transfer the motor power to a second load or to manually rotate it when the motor is not energized.



Canopy

It is used for operation in the outside environment where the motor fan is pointing upwards. This prevents the rainwater from entering the motor housing.

Brake, Hand Release, Separately Driven Fan Encoder and Backstop



Electromagnetic Brake

For each motor size we have the option of electromagnetic brake. Brakes with 24 Volt, 230 Volt and 400 Volt DC from 5Nm to 1600Nm are alternatively can be used as needed.

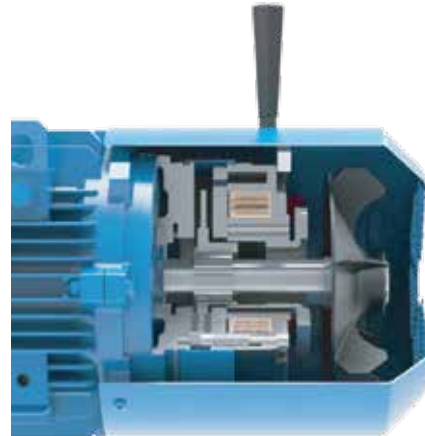

Brake with Hand Release

Hand release on the brake is used to release the system when the power is cut off or the power is not turned on.



Separately Driven Fan

Separately driven fan is used particularly in applications where the motor is driven by variable speed drives to keep the air flow at a constant level.



Separately Driven Fan with Encoder

In applications where synchronous operation is desired, encoder application is used. The motor fan cannot be used since the encoder is mounted on the non drive end cover. For this reason, the motor is cooled by a separately driven fan.



Separately driven fan with brake and encoder

In applications where both brake and synchronous operation are desired, brake, encoder and separately driven fan options are all mounted to the non drive side of the motor.



Backstop

Backstop is used when the motor should rotate only in one direction and the motor should not rotate in the other direction. The backstop option in the fan cover is widely used.

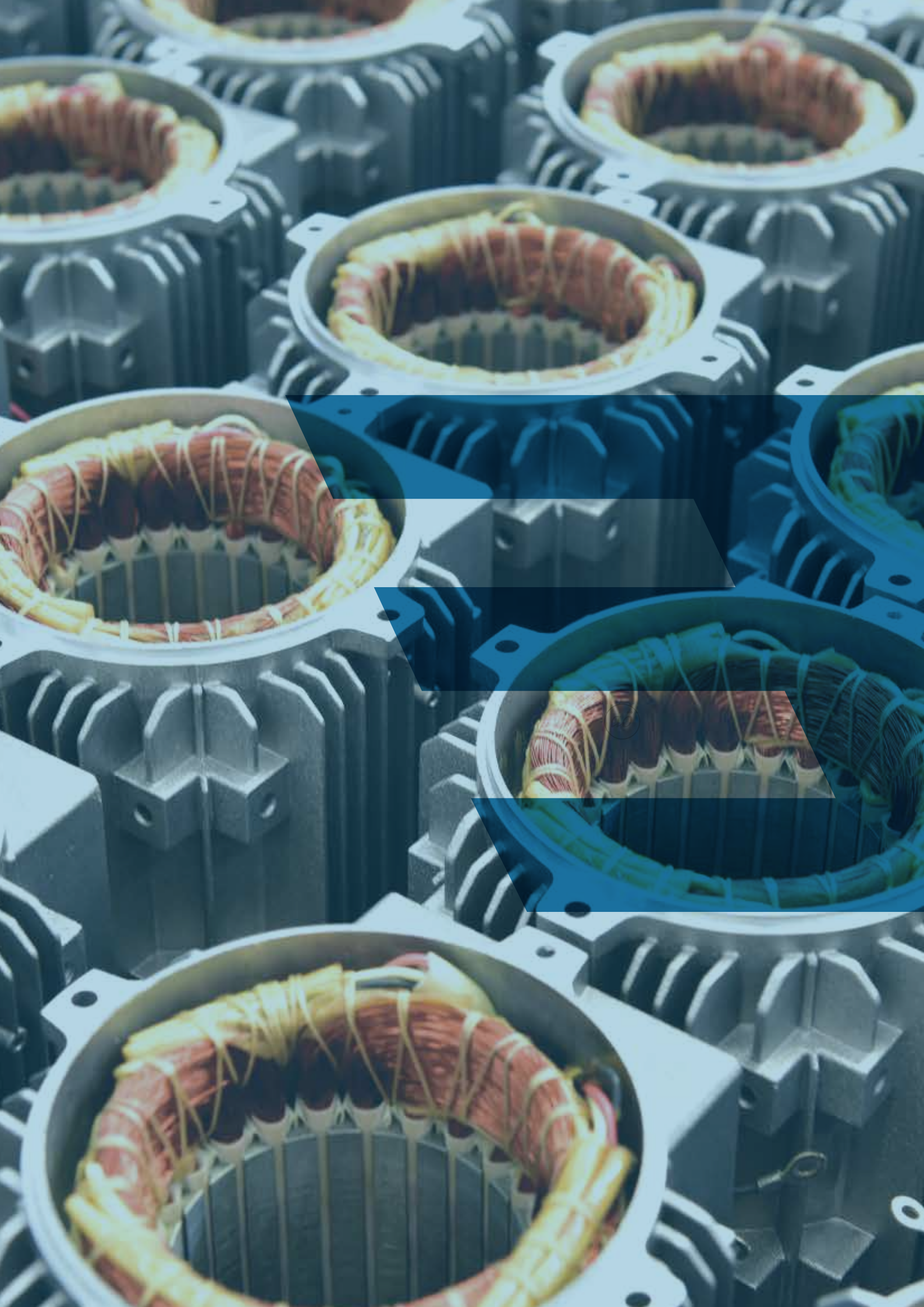

ELK
MOTOR

Sales Office:

Atatürk Mah. Lozan Cad. No: 17, 34522 Esenyurt / İSTANBUL
Phone: 444 95 60 Fax: +90 212 886 54 58
www.elkmotor.com.tr | elkmotor@elkmotor.com.tr

**Factory
[Headquarters]:**

G.O.Paşa Mah. 1. Cad. 2. Organize Sanayi Bölgesi No: 125
59500 Çerkezköy / TEKİRDAĞ
Phone: 444 95 60 Fax: + 90 282 726 90 42